

TERRA POWER ATTACHMENTS

SG25 STUMP GRINDER FOR SKID STEER LOADERS

POWER..
PERFORMANCE..
SIMPLICITY



TERRA Power Attachments **SG25** Stump Grinder Attachment has the productivity and features to make quick and easy work of any stump removal job. Whether you are a pro or not, you'll feel like one when you see how easy it is to operate and maintain the **SG25**.

TERRA designed the **SG25** with performance and simplicity in mind while maintaining the highest quality. The **SG25** maximizes the versatility and the return on investment of your skid steer by turning it into a powerful stump grinding machine.

- **HYDRAULIC DEPTH AND SWEEP** IS CONTROLLED SMOOTHLY BY A MANUALLY ACTUATED SPOOL VALVE FOR PRECISE CONTROL AND FEEL.
- **HYDRAULIC HEAD EXTENSION** (8 IN) PROVIDES THE MANEUVERABILITY WITHOUT HAVING TO RE-POSITION THE LOADER
- **SELF LEVELING FOOT PADS** PROVIDE POSITIVE STABILIZATION ON UNEVEN TERRAIN
- **CHIP GUARD** CONTAINS WOOD CHIPS AND DEBRIS SAFELY AROUND STUMP
- **ADJUSTABLE CONTROL ARM** FOLDS OUT OF THE WAY FOR EASY ACCESS.
- **SINGLE PIECE CUTTING TEETH** SIMPLY BOLT ON AND OFF WITH NO ADJUSTMENT OR GAUGING REQUIRED
- **DIRECT DRIVE HYDRAULIC MOTOR** PROVIDES DEPENDABLE, EFFICIENT SERVICE AND REDUCES MAINTENANCE REQUIREMENTS.
- **WIDE 86° CUTTING ARC** PROVIDES MAXIMUM CAPACITY .

TERRA POWER ATTACHMENTS, INC

6680 EAST RIDGEWAY DRIVE
MOORESVILLE, IN 46158

PH: 1-866-340-3772 FAX: 317-834-2376

TERRA POWER ATTACHMENTS

SG25 STUMP GRINDER FOR SKID STEER LOADERS

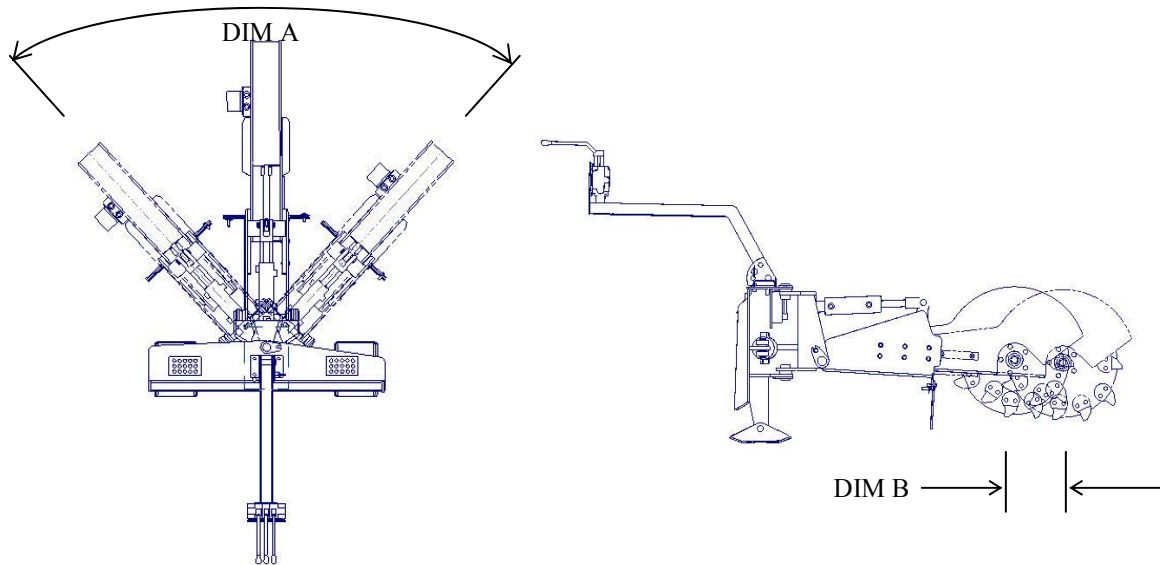

SPECIFICATIONS		
	SG25	SG45
MINIMUM FLOW	14 GPM	22 GPM
MAXIMUM FLOW	23 GPM	35 GPM
PRESSURE (MAX)	3000 PSI	3800 PSI
CUTTING HEIGHT (RETRACTED)	22 IN	22 IN
CUTTING HEIGHT (EXTENDED)	26 IN	26 IN
CUTTING HEAD EXTENSION (DIM B)	8 IN	8 IN
CUTTING ARC (DIM A)	86°	86°
CUTTING DEPTH (EXT/RET)	14 IN/12 IN	14 IN/12 IN
WEIGHT	700 LBS.	710 LBS
CONTROLS	MANUAL OVER HYDRAULIC	MANUAL OVER HYDRAULIC

STANDARD FEATURES

- ◆ **HYDRAULIC SWEEP, DEPTH AND EXTENSION FUNCTIONS** MAKE STUMP REMOVAL QUICKER AND MORE EFFICIENT
- ◆ **ADJUSTABLE PRIORITY FLOW DIVIDER** LETS YOU TUNE THE AMOUNT OF OIL AVAILABLE TO THE FUNCTION CONTROLS TO YOUR INDIVIDUAL PREFERENCE
- ◆ **OPERATOR ADJUSTABLE CONTROL VALVE ARM** PROVIDES COMFORT AND REDUCES FATIGUE
- ◆ **SELF LEVELING FOOT PADS** LET YOU STABILIZE THE UNIT ON UNEVEN TERRAIN
- ◆ **CHIP GUARD** SAFELY CONTAINS CHIPS AND DEBRIS AROUND THE STUMP.
- ◆ **ONE PIECE CUTTING TEETH** SIMPLY BOLT ON AND OFF WITH NO GAUGES OR ADJUSTMENT REQUIRED

For more information or to place an order call:

TOLL FREE 1-866-340-3772

SPECIFICATIONS SUBJECT TO CHANGE WITHOUT NOTICE.

TERRA POWER ATTACHMENTS, INC

6680 EAST RIDGEWAY DRIVE
MOORESVILLE, IN 46158

PH: 1-866-340-3772 FAX: 317-834-2376